



GUIDE D'INSTALLATION INSTALLATION GUIDE

AVIS IMPORTANT

SVP bien lire les instructions avant de débiter l'installation.

NE PAS DÉBALLER LES PANNEAUX AVANT D'ÊTRE PRÊT À LES INSTALLER.

Si les panneaux déballés ne sont pas installés le même jour, il est nécessaire de les entreposer à plat par terre.

Garantie :

InsulFloor est garanti à vie contre tous les défauts de fabrication. Les matériaux défectueux devront être retournés au fabricant et seront remplacés sans frais.

IMPORTANT NOTICE

Please read the instructions carefully before beginning your project.

DO NOT UNPACK THE PANELS UNTIL READY TO INSTALL.

If the unpacked panels are not installed the same day, it is important to store them flat on the floor.

Guarantee :

InsulFloor is guaranteed for life against all manufacturing defects. Defective material should be returned to the manufacturer and will be replaced without cost.

1

OUTILLAGE - TOOLS

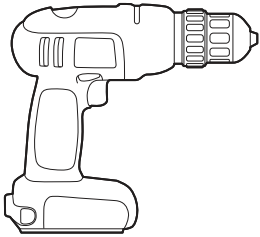

Perceuse
Drill

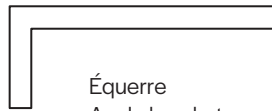

Équerre
Angle bracket

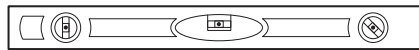

Niveau
Level

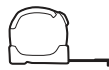

Gallon à mesurer
Tape measure



Cordeau à craie
Chalkline



Couteau
Hammer



Spatule
Trowel

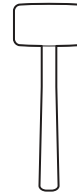

Maillet
Hammer

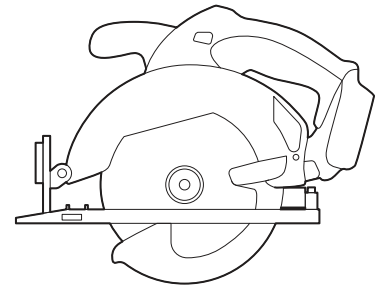

Scie circulaire
Circular saw

2

QUANTITÉ - QUANTITY

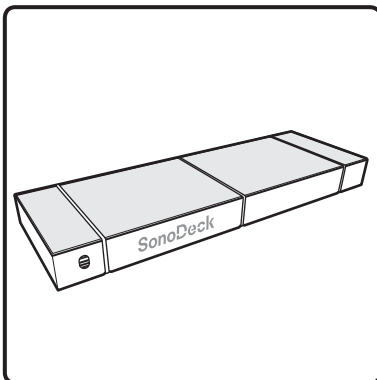

1 paquet
1 package

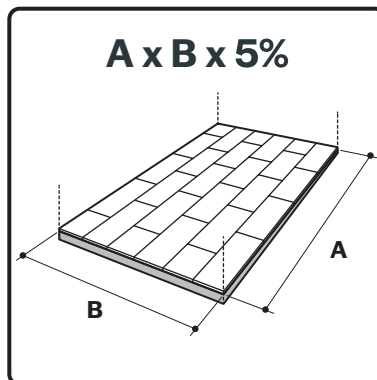

Quantité minimum
Minimum quantity

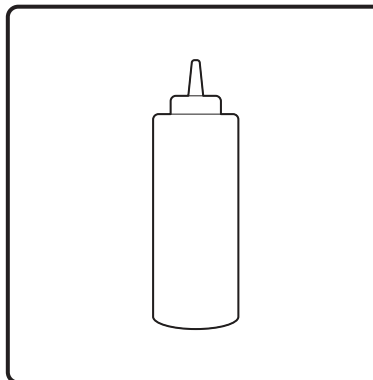

Colle blanche à menuiserie
White carpenter's glue

3**DALLE DE BÉTON OU STRUCTURE DE BOIS - CONCRETE SLAB OR WOODEN STRUCTURE**

Pas de débris, ni d'humidité
Remove debris, neither humid

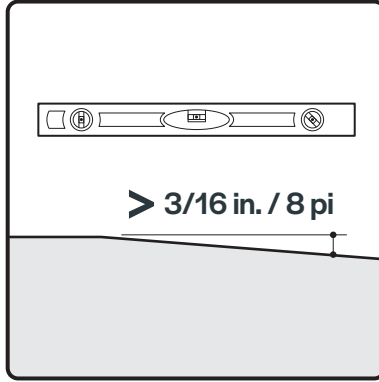

Inspecter le niveau du sol
Inspect the level of floor

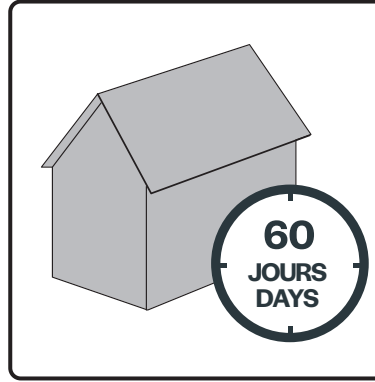

Nouvelle dalle de béton
New concrete slab

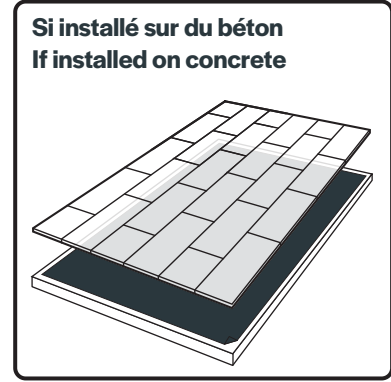

Installer un pare-vapeur
Install a vapor barrier

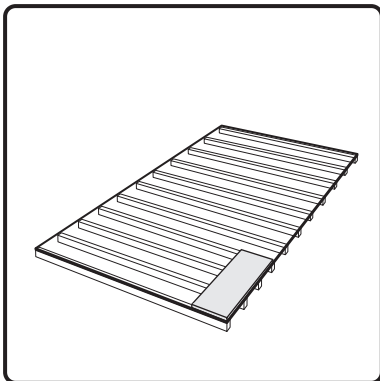
4**INSTALLER - FIRST ROW**

Installation perpendiculaire aux solives
Installation perpendicular to joists

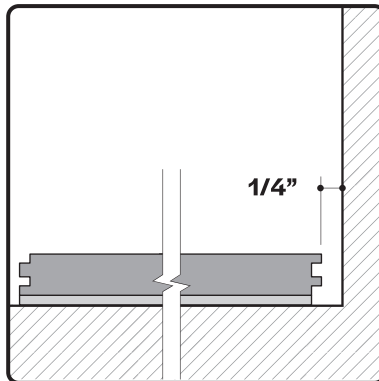

La partie femelle vers le mur
The female part towards the wall

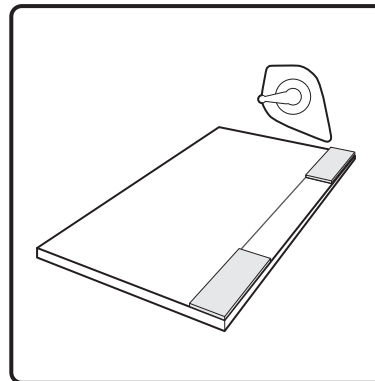

Tirer une ligne de craie
Draw a chalk line

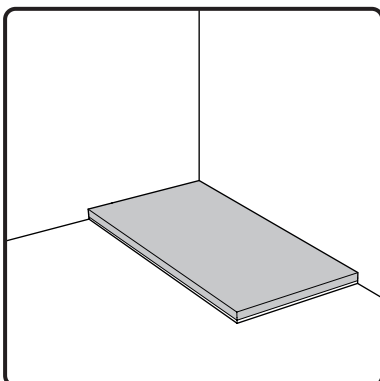

Installation flottante du Sonodeck
Floating installation of the Sonodeck

5**APPLICATION DE LA COLLE - APPLYING THE GLUE**

Déposer les panneaux à 1/4" du mur
Place the panel a 1/4" away from walls

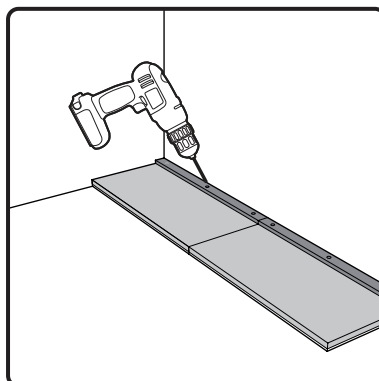

Stabiliser la première rangée
Stabilize the first row

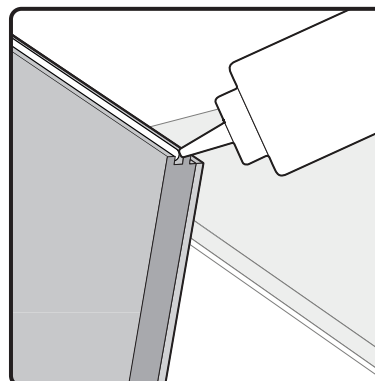

Déposer un filet de colle dans la rainure du panneau
Apply a line of glue in the concave part of panel

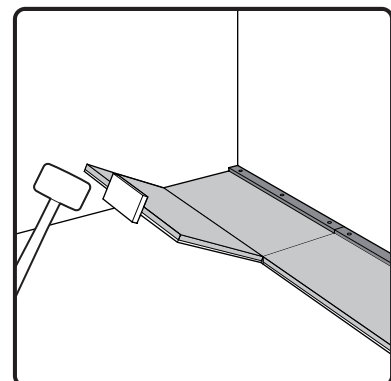

Emboveter les panneaux
Join tongue and groove together

InsulFloor

INSULFLOOR.COM | 1 877 664 6662

6 RANGÉES SUBSÉQUENTES - SUBSEQUENT ROWS



Schéma du plancher
Floor plan



Décaler les joints
Stagger the joints

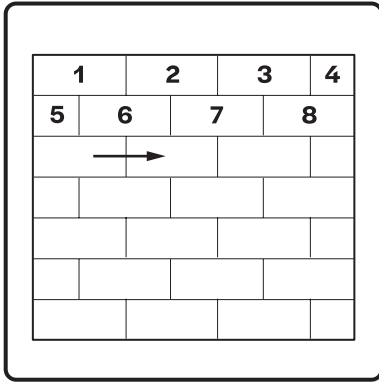
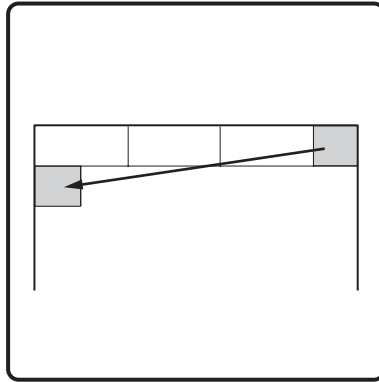
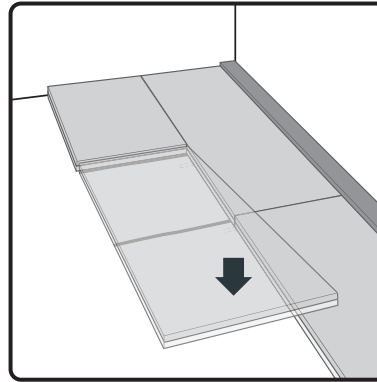

Répéter les étapes 5, 6 et 7
Repeat steps 5, 6 and 7

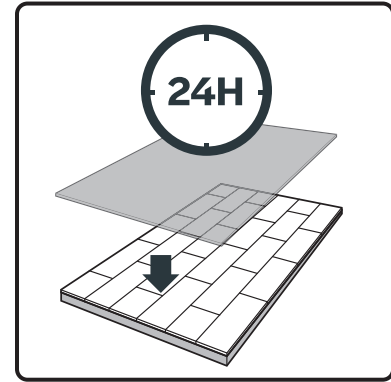

Attendre 24h pour la pose du revêtement
Wait 24 hours for installing floor covering

7 RECOMMANDATIONS - RECOMMENDATIONS

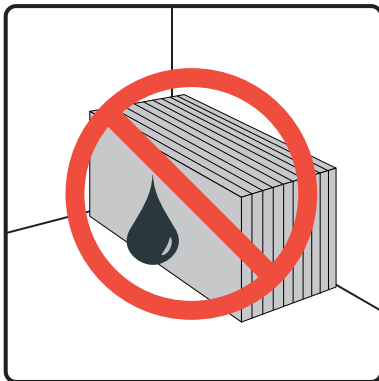

Ne pas entreposer à la verticale
Do not store vertically

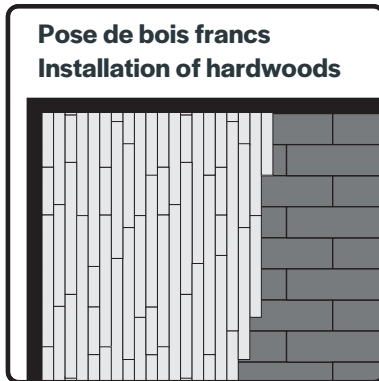

Installation perpendiculaire
Perpendicular installation

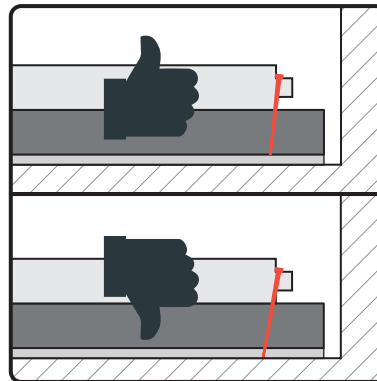

Le clou doit arrêter avant la membrane de fibre de verre
The nail needs to stop before the fiberglass

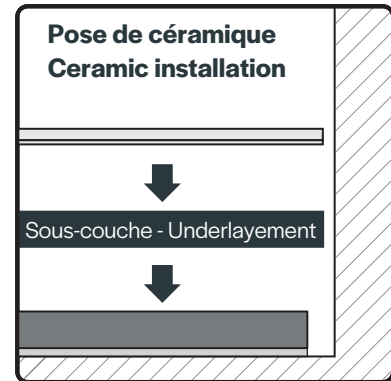

Ajouter sous-couche approuvée
Add approved underlayment



IT IS RECOMMENDED TO ALWAYS FOLLOW THE INSTALLATION DIRECTIONS OF THE FLOOR COVERINGS.
IL EST RECOMMANDÉ DE TOUJOURS SUIVRE LE MODE D'INSTALLATION DES REVÊTEMENTS DE SOL

- * Insulfloor is not responsible for the final installation of the floor covering.
Insulfloor n'est pas responsable de l'installation finale du couvre plancher.